

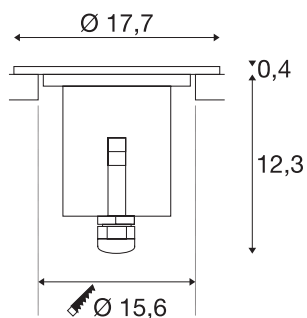

DASAR 180 PREMIUM

outdoor inground fitting, LED, 3000K, IP67, round, bezel stainless steel, 38°, Ø/H 17.7/12.71 cm, 32W

The high-voltage DASAR Premium LED 180 inground light is accessible and impresses with its stainless steel screen and glass cover in a partial satin finish. Its cover is 5 times harder and 100 times more scratch resistant than ordinary glass. The housing is made of high-quality aluminium and 316 stainless steel. Experience light with SLV – your reliable partner for all kinds of outdoor lights for 40 years.



TECHNICAL DATA

Item no.	233756
IP Code	IP 67
Impact resistance class	IK 08
Impact resistance	5 Joule
Assembly	Recessed
Assembly details	Ground
Mechanical loading	2 t
Primary nominal voltage	220-240V ~50/60Hz
Secondary power / voltage	750 mA
Safety class	I
Wattage	32 W
Maximum ambient temperature	40 °C
Temperature at glass (light emission)	65 °C
Lumen	3000 lm
Colour temperature	3000 Kelvin
Beam angle	38 °
Color	stainless steel
CRI	80
LXXBXX data	L70B50
Service life	30000 h
Light outlet	direct
Depth	12.7 cm

Diameter	17.7 cm
Net weight	3.084 kg
Gross weight	3.214 kg
Shape of cut-out	round
Installation depth	16.4 cm
Installation diameter	15.6 cm

Accessories

228726	T-CONNECTION BOX , black, IP68
1000655	Inground mounting pot , black for DASAR® PRE- MIUM and GIMBLE OUT